

ZAWÓR ZAPOROWY MIESZKOWY grzybkowy, kołnierzowy		КЛАПАН ЗАПОРНЫЙ СИЛЬФОННЫЙ флянцевый		STOP VALVE WITH BELLOWS with plug, flanged	
PN16 (1,6 MPa)	DN 15 - 250	prosty Прямой a straight-way form		Fig. 234	
PN25 (2,5 MPa)	DN 15 - 200				
PN40 (4,0 MPa)	DN 15 - 150				
PN16 (1,6 MPa)	DN 15 - 250	kątowy / Угловой / angle form		Fig. 235	
PN25 (2,5 MPa)	DN 15 - 200				

ZASTOSOWANIE

Woda przemysłowa zimna i gorąca, para wodna, czynniki obojętne.

ZALETY

- wysoki stopień szczelności,
- nieobrotowy trzpień,
- wskaźnik otwarcia,
- bezpieczny ekologicznie.

ПРИМЕНЕНИЕ

Для холодной и горячей промышленной воды, для пара, для неагрессивных сред

ДОСТОИНСТВА

- высокий уровень плотности закрытия,
- невращающийся шпindelъ,
- Указатель открытия,
- безопасен для окружающей среды.

APPLICATION

Industrial cold and hot water, steam, neutral fluids.

ADVANTAGES

- high tightness,
- non-turning stem,
- stroke indicator,
- environment-friendly.

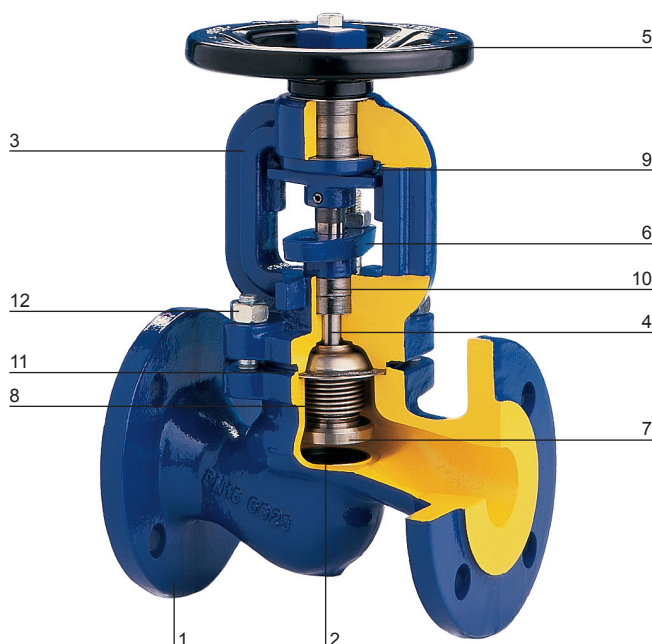

MATERIAŁY • МАТЕРИАЛЫ • MATERIALS

	PN16, PN25		PN40*
	Fig. 234A, Fig. 235A	Fig. 234C, Fig. 235C	Fig. 234F
1. Kadłub / Корпус / Body	EN-GJL-250 JL1040	EN-GJS-400-18-LT JS1025	GP240GH
2. Pierścień kadłuba / Кольцо корпуса / Seat ring	X12Cr13 1.4006		
3. Pokrywa / Крышка / Bonnet	EN-GJL-250 JL1040	EN-GJS-400-18-LT JS1025	GP240GH
4. Trzpień / Шпindelъ / Stem	X20Cr13 1.4021		
5. Kółko / Маховик / Handwheel	Stal / Сталь / Steel		
6. Dławik / Сальник / Gland	EN-GJS-500-7 JS-1050		
7. Grzyb / Клапан / Disc	X6CrNiMoTi-17-12-2 1.4571		X20Cr13 1.4021
8. Mieszek / Сильфон / Bellow			X6CrNiMoTi-17-12-2 1.4571
9. Tulejka / Втулка / Sleeve	EN-GJS - 500-7 JS1050		
10. Uszczelnienie dławnicy / Уплотнение сальника / Gland packing	Grafit / Графит / All-graphite		
11. Uszczelka pokrywy / Прокладка крышки / Bonnet gasket	Graphit - CrNiSt		
12. Śruba z łbem sześciokątnym / Шестигранный болт / screw with hexagonal nut	8.8	A2-70	
Max. temperatura pracy / Макс. рабочая температура / Max. working temperature	300 °C	350 °C	400 °C
kadłub+pokrywa / Корпус+Крышка / Body + bonnet A ⇒ EN-GJL-250 (GG25), C ⇒ EN-GJS-400-18-LT (GGG40.3), F ⇒ GP240GH			

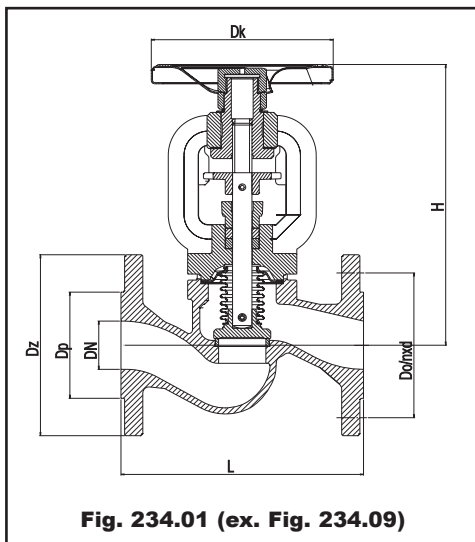

Z grzybem dławiącym /
С дроссельным клапаном / With throttling disc

DN 15-200

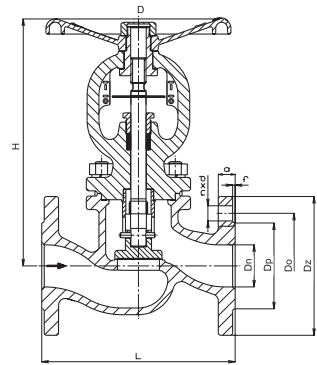
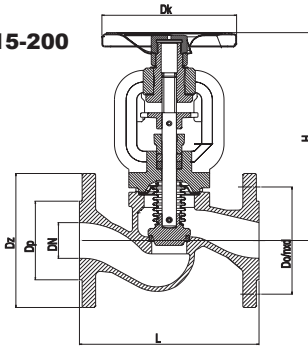

DN	PN16				PN25				PN16, PN25				PN16, PN25								
	Fig. 234, Fig. 235				Fig. 234				Fig. 234		Fig. 234		Fig. 235								
	Dz	Dp	Do	nxd	Dz	Dp	Do	nxd	Dk	h	L	H	K _s	kg	K _s	kg	L	H	K _s	kg	kg
mm				mm				mm		mm		m ³ /h	kg	m ³ /h	kg	mm		m ³ /h	kg	kg	
15	95	45	65	4x14	95	46	65	4x14	125	5	130	175	5,9	3,8	3,4	3,8	90	255	7,2	3,8	3,8
20	105	58	75	4x14	105	56	75	4x14	125	5	150	175	7,4	4,5	6,3	4,5	95	260	9,2	4,3	4,3
25	115	68	85	4x14	115	65	85	4x14	125	7	160	185	13,0	5,3	9,4	5,4	100	270	16,0	5,3	5,4
32	140	78	100	4x19	140	76	100	4x19	125	8	180	195	18,0	7,0	16,0	7,2	105	280	22,0	7,0	7,2
40	150	88	110	4x19	150	84	110	4x19	150	10	200	235	30,0	9,7	26	10,0	115	330	37,0	9,5	9,8
50	165	102	125	4x19	165	99	125	4x19	150	13	230	235	41,0	13,3	40	13,8	125	345	51,0	12,0	13,0
65	185	122	145	4x19	185	118	145	8x19	175	16	290	270	79,0	18,5	70	19,0	145	390	98,5	16,5	17,0
80	200	138	160	8x19	200	132	160	8x19	200	20	310	310	115	24,5	106	25,4	155	425	143	22,0	22,8
100	220	158	180	8x19	235	156	190	8x23	225	25	350	370	181	37,5	170	38	175	505	226	33,5	35
125	250	188	210	8x19	270	184	220	8x28	250	32	400	420	225	54	245	56,5	200	580	291	49	50,5
150	285	212	240	8x23	300	211	250	8x28	400	40	480	505	364	78	360	80,0	225	675	455	71	73
200	340	266	295	12x23	360	274	310	12x28	400	50	600	596	725	130,5	-	130,5	275	-	625	110,5	-
250	405	319	355	12x28	-	-	-	-	400	65	730	667	-	130,5	-	-	-	-	625	-	-

h - Skok grzyba / Ход клапана / Stroke

Fig. 234F - PN 40										
DN	Dz	Dp	Do	nxd	L	H	h	Dk	kg	K _s
mm										m ³ /h
15	95	45	65	4x14	130	189	6	120	4,3	4,3
20	105	58	75	4x14	150	189	6	120	5,1	7,0
25	115	68	85	4x14	160	189	6	120	5,8	11,0
32	140	78	100	4x18	180	220	10	160	9,5	17,5
40	150	88	110	4x18	200	220	10	160	9,8	27,0
50	165	102	125	4x18	230	295	16,5	195	17,5	47,0
65	185	122	145	8x18	290	295	16,5	195	20,5	68,0
80	200	138	160	8x18	310	368	25	280	34,0	116,0
100	220	158	180	8x22	350	368	25	280	44,0	162,0
125	270	188	220	8x26	400	523	40	350	77,0	250,0
150	285	212	240	8x26	480	523	40	350	110,0	364,0

Na życzenie klienta /
По желанию клиента /
On customer's request

DN15 - 150
Max. temperatura pracy /
Макс. рабочая температура
/ Max. working temperature
200°C

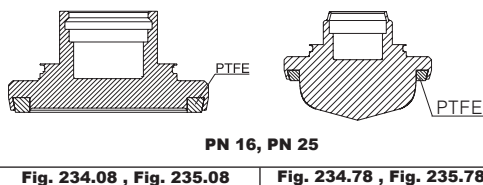

EN 1092 - 2							
Ciśnienie - temperatura Давление - Температура Pressure - temperature							
EN-GJL-250		EN-GLS-400-18-LT				GS-C25 (1.0619)	
PN16		PN16		PN25		PN40	
°C	bar	°C	bar	°C	bar	°C	bar
-10	16	-10	16	-10	25	-50	-
120	16	120	16	120	25	-20	40
150	14,4	150	15,5	150	24,3	120	40
180	13,4	200	14,7	200	23	200	35
200	12,8	250	13,9	250	21,8	250	32
230	11,8	300	12,8	300	20	300	28
250	11,2	350	11,2	350	17,5	350	24
300	9,6	-	-	-	-	400	21

Kolnierze Фланцы Flanges	EN 1092 - 2
Długość zabudowy Длина застройки Face to face lenght	EN 558-1 → 1-Fig. 234, 8-Fig. 235 (DIN 3202 → F1-Fig. 234, F32-Fig. 235)

PRZYKŁAD ZAMÓWIENIA
ПРИМЕР ЗАКАЗА
ORDER EXAMPLE

234C040C01

Figura / Фигура / Figure	234
Material kadłuba / Материал корпуса / Body material	C
Średnica nominalna / Номинальный диаметр / Nominal diameter	040
Ciśnienie nominalne / Номинальное давление / Nominal pressure	C
Wykonanie / Исполнение / Type	01